

**Temperature Compensated Crystal Oscillators TCXO,
MW57P Series, +3.3V "W" Family PECL Outputs**



MERCURY
Since 1973

Features:

- ◆ 5x7x2.8 mm ceramic SMD TCXOs with PECL differential output
- ◆ 0.01 uF decoupling capacitor built-in
- ◆ Wide frequency range: 10 MHz to 800 MHz
- ◆ Low cost, low jitter, general purpose



General Specifications (at +25°C and specified input voltage)

Product Series		MW57P. "W" family characteristics						
Frequency Range		12.0 MHz ~ 800.0 MHz						
Output Wave From		Differential PECL Square wave. Wave form code is "P"						
Initial Calibration Tolerance ⁽¹⁾		±2 ppm at +25°C±2°C and Vcon = +1.65 V D.C.						
Frequency Stability vs operating temperature vs Aging vs Voltage Change vs Load Change vs Reflow		±2.5 ppm over -30 to +80°C (Custom spec. are available) ±1.0 ppm max. first year at +25°C ±0.3 ppm max. for a ±5% input voltage change ±0.3 ppm max. for a ±10% loading condition change ±1 ppm max. 1 reflow and measured 24 hours afterwards						
Supply Voltage (V_{DD})		+3.3 V ±5% (voltage code is "33")						
Current Consumption		10 MHz ≤ f _{out} < 25 MHz: 65 mA max.; 25 MHz ≤ f _{out} < 100 MHz: 85 mA max; 100 MHz ≤ f _{out} ≤ 800 MHz: 115 mA max; (Measured with a PECL Thevenin equivalent load).						
Output Voltage Levels	Logic High	V_{OH}: 2.275 V min. Condition: 50 Ω to (V _{DD} -2V).						
	Logic Low	V_{OL}: 1.680 V max. Condition: 50 Ω to (V _{DD} -2V).						
Rise Time and Fall Time		2 nano. sec. max. 20% ↔ 80% of waveform						
Duty Cycle (Symmetry)		50%±5% measured at 50% of waveform						
Start-up Time		5 m. sec. max.						
Pad 1		No connection						
Pad 2: Tri-state Function	No Connection	Differential PECL and complimentary PECL outputs.						
	Disable	Both outputs are disabled (high impedance) when pad No. 2 is taken below 0.45 * Vcc referenced to ground (threshold). Oscillator is always ON. Only buffer stage is disabled. Disable current: 50 uA max. (at 0.0 V). Disable time: 10 ns max.						
	Enable	At disabled mode, both outputs are enabled when pad No. 2 is taken above 0.45 * Vcc referenced to ground (threshold). Enable time: 10ns+one period of the output frequency max.						
Output Load		50 ohms into V _{CC} -2V or Thevenin equivalent (terminating resistors required on all outputs). See test circuit below.						
Aging		±1 ppm per year max.						
SSB Phase Noise (dBc/Hz)	Offset	10 Hz	100 Hz	1 kHz	10 kHz	100 kHz	1 MHz	10 MHz
	MW57P33-19.440	-80	-108	-132	-142	-150	-150	-152
	MW57P33-77.760	-72	-103	-122	-130	-125	-125	-143
	MW57P33-155.520	-65	-95	-120	-125	-121	-120	-140
	MW57P33-311.020	-59	-86	-116	-129	-124	-140	-148
MW57P33-622.080	-55	-85	-109	-115	-110	-110	-128	

MERCURY www.mercury-crystal.com

Taiwan: TEL (886)-2-2406-2779, FAX (886)-2-2496-0769, e-mail: sales-tw@mercury-crystal.com

U.S.A.: TEL (1)-909-466-0427, FAX (1)-909-466-0762, e-mail: sales-us@mercury-crystal.com



Jitter		Period Jitter (RMS)	Period Jitter (peak-to-peak)	Integrated Jitter RMS (12 KHz ~20 MHz)
	MW57P33-19.440	2.2 ps typ; 4.0 ps max	17 ps typ.; 20 ps max.	2.0 ps typ; 3.0 ps max.
	MW57P33-77.760	3.5 ps typ; 5.3 ps max	25 ps typ.; 28 ps max	2.7 ps typ; 4.0 ps max.
	MW57P33-155.520	4.3 ps typ; 6.1 ps max	27 ps typ.; 30 ps max	2.6 ps typ; 4.0 ps max.
	MW57P33-311.020	4.5 ps typ. 6.3 ps max	22 ps typ.; 25 ps max	2.6 ps typ; 4.0 ps max.
MW57P33-622.080	5.0 ps typ.;6.8 ps max	32 ps typ.; 35 ps max	2.5 ps typ; 4.0 ps max.	
Packaging	179 mm reel, 16 mm tape, 8.0 mm pitch, 1000 pcs per reel.			
Contact Pad Surface Finish	Gold over nickel on ceramic substrate			

MW57P33 TCXO Test Circuit and Output Wave Form:

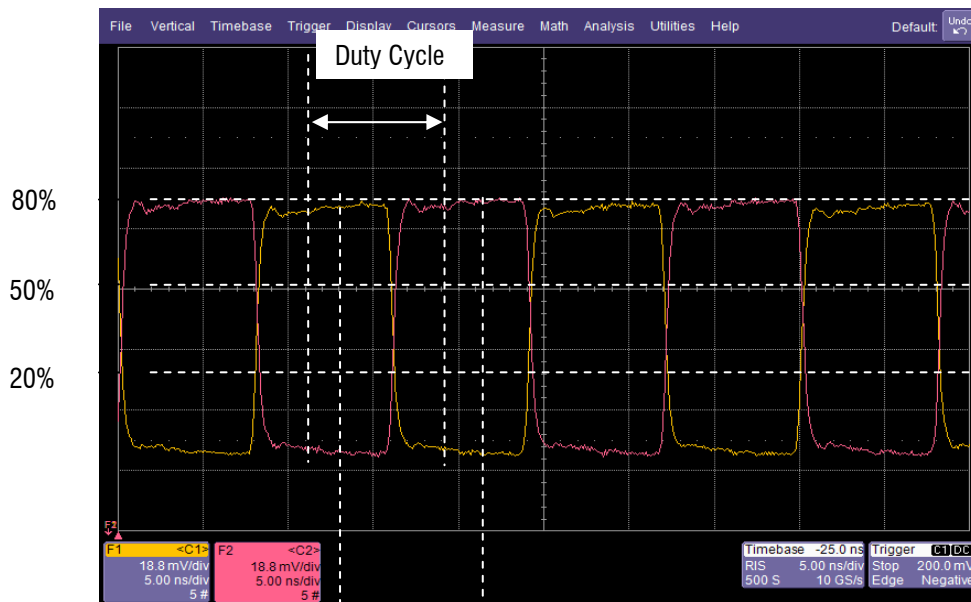
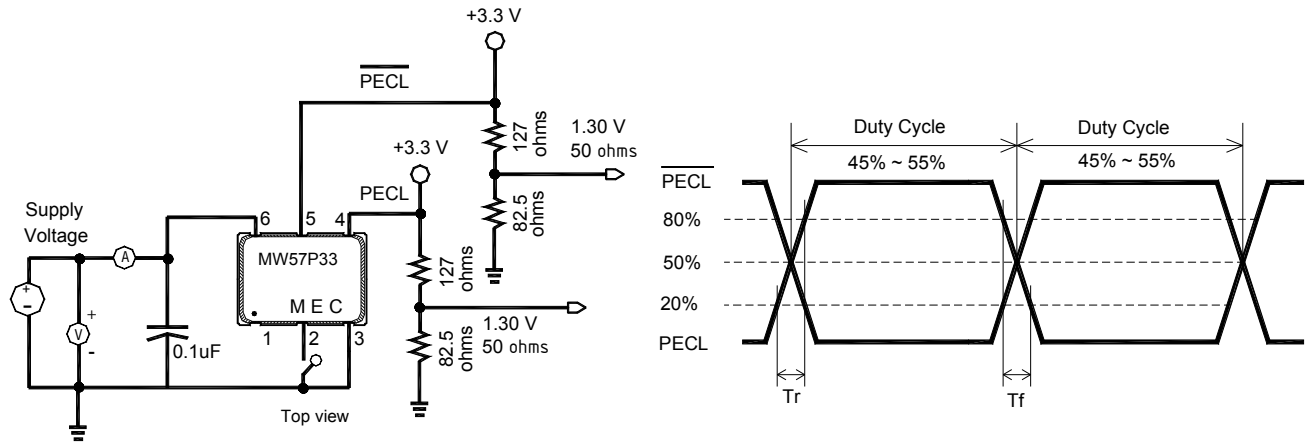

**Temperature Compensated Crystal Oscillators TCXO,
MW57P Series, +3.3V "W" Family PECL Outputs**



MERCURY
Since 1973

Environment Performance Specifications

Green Requirement	RoHS compliant, Pb (lead) free
Humidity	85% RH, 85°C, 48 hours
Hermeticity	Leak rate 2×10^{-8} ATM-cm ³ /sec max. Crystal part only.
Solderability	MIL-STD-202F method 208E
Vibration	MIL-STD-202F method 204, 35G, 50 to 2000 Hz
Shock	MIL-STD-202F method 213B, test condi. E, 1000GG 1/2 sine wave
Storage temp. range	-55 to +125°C

Package Dimensions and Suggested Land Pattern: Unit: mm

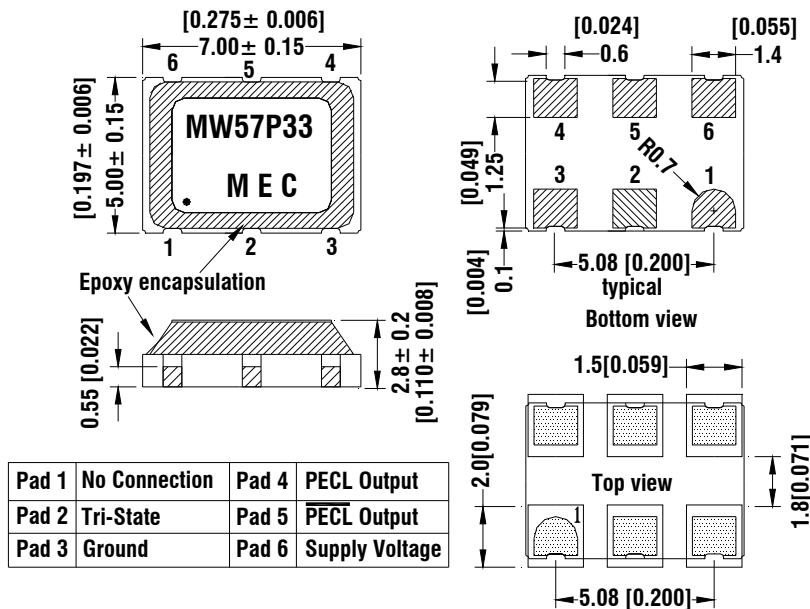

Pad 1	No Connection	Pad 4	PECL Output
Pad 2	Tri-State	Pad 5	PECL Output
Pad 3	Ground	Pad 6	Supply Voltage

Rounded pad is pad No. 1. Count counter-clockwise when looking at top view.
Count clockwise when looking at bottom view. 0.01 uF decoupling capacitor is built-in.

Part Number Format and Example:

Part number example: MW57P33-80.000-2.5/-30+75						≠ = Please specify					
M	W	57	P	33	—	80.000	—	2.5	/	-30+75	
①	②	③	④	⑤		⑥		⑦		⑧	
①: "M" for TCXO; "VM" for VCTCXO			④: "P" for PECL output;			⑤: "33": for +3.3 V;			⑧: Operating Temperature range in °C		
②: "W": W family performance			⑦: Frequency stability in ppm;			③: "57": 5x7 mm SMD;			⑥: Frequency in MHz		



Recommended Solder Reflow Profiles

245°C liquidus 221°C solidus solder alloy is used in the assembly of MW57 products.
Do not exceed the reflow conditions given below.

Profile A (low temperature solder reflow): For Sn62 Pb36 Ag2 and Sn63 Pb37 alloy.

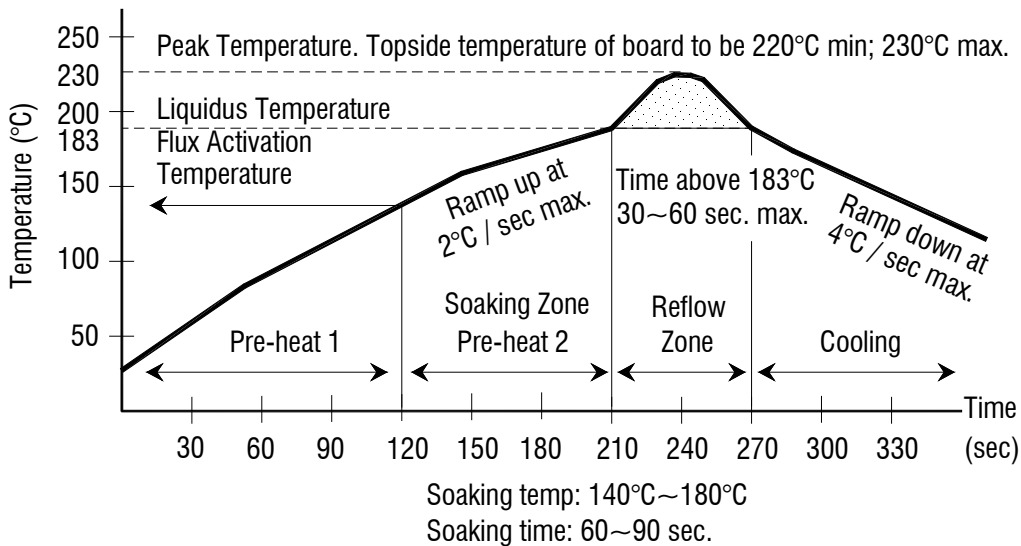

Profile B (high temperature solder reflow): For Sn96.5% Ag 3.5% Cu 0.5% alloy.

