

Dipped Radial Lead Type

● Part Number Description

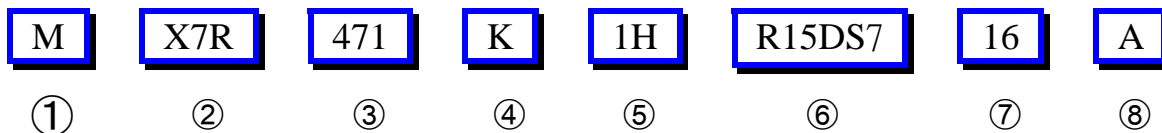

① Type

Symbol	Type
M	Radial

② Temperature Characteristic

Temp. Charact.	Temperature Range	Capacitance Change
NPO	-55 ~ 125°C	0±30 ppm/°C
X5R	-55 ~ 85°C	±15%
X7R	-55 ~ 125°C	±15%
Y5V	-30 ~ 85°C	+22%, -82%
Z5U	+10 ~ 85°C	+22%, -56%

③ Capacitance Value

Symbol	Cap. Value
060	6pF
6R8	6.8pF
120	12pF
471	470pF
222	2200pF
104	100000pF

④ Capacitance Tolerance

Symbol	Cap. Tol.
C	±0.25pF
D	±0.5pF
F	±1%
G	±2%
J	±5%
K	±10%
M	±20%
Z	+80%, -20%

⑤ Rated Voltage

Symbol	Rated Voltage
0J	DC 6.3V
1A	DC 10V
1C	DC 16V
1E	DC 25V
1H	DC 50V
2A	DC 100V
2E	DC 250V
2H	DC 500V

Dipped Radial Lead Type

⑥ Style

Symbol	Dimension (unit:mm)				
	W(max)	L(max)	T(max)	F(±0.8)	Φd
R15AS2	4.5	4.5	3	2.5	0.55 ±0.05
R15AS5	4.5	4.5	3		
R18AS2	5.5	5.5	3.5		
R15DS5	4.5	4.5	3	5	
R15DS6	4.5	4.5	3		
R18DS6	5.5	5.5	3.5		
R15DS7	4.5	4.5	3		
R18DS7	5.5	5.5	3.5		

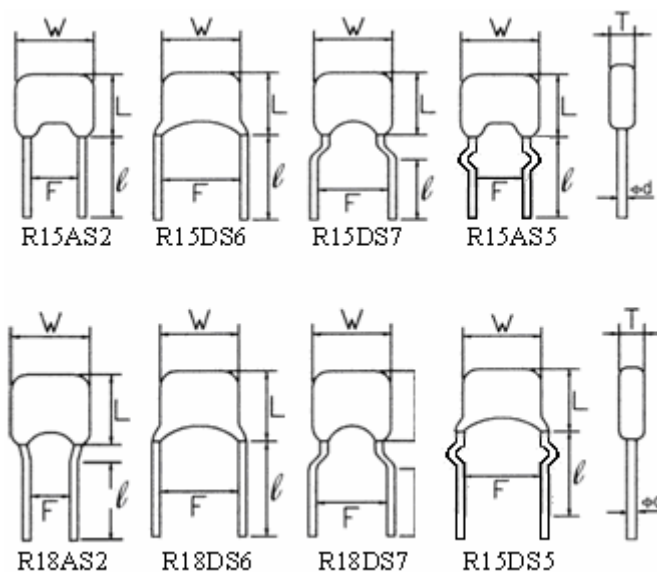

⑦ Lead Length (ℓ)

Symbol	06	10	16	30	04
Length (mm)	6±1	10±1	16± ₁ ^{1.5}	30±3	4±1

⑧ Packing

Symbol	Packing
Blank	Bulk
A	AMMO
R	REEL

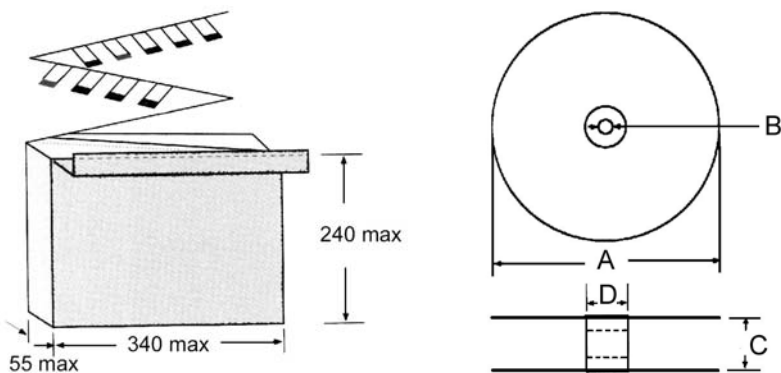

Reel Package

Unit:mm

A	B	C	D	
365max.	28±1.5	51.0max.	102max.	

Dipped Radial Lead Type

- Taping

(Refer to ⑥ Style)

R□□DS□
Style

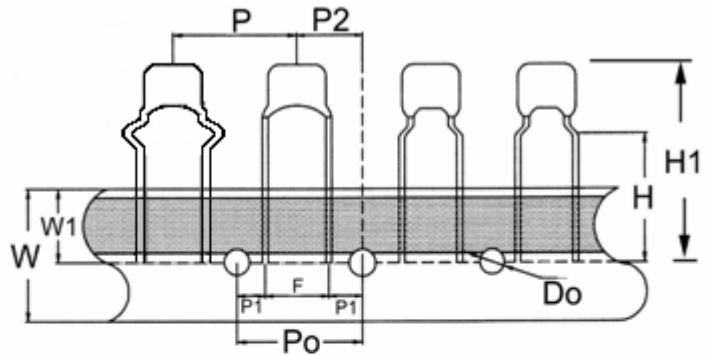

R□□AS□
Style

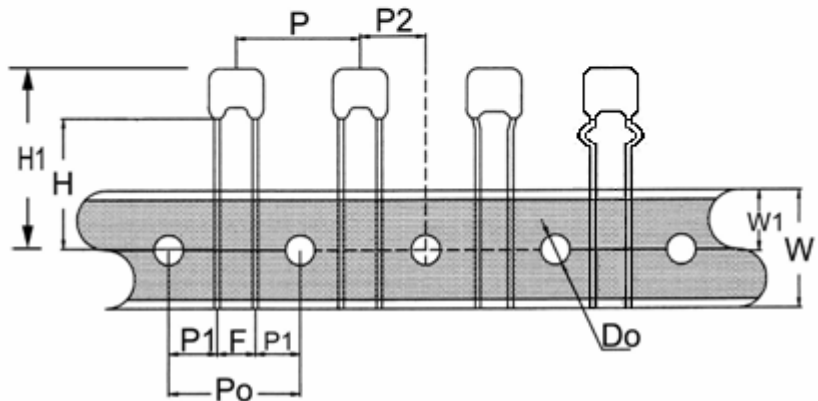

Unit:mm

Description		R□□AS□ Style	R□□DS□ Style	Remark
Carrier tape width	W	18±0.5		
Position of sprocket hole	W1	9±0.5		
Pitch of component	P	12.7 Ref.		
Pitch of sprocket hole	P0	12.7±0.3		
Length from hole center to Lead	P1	5.1±0.7	3.85±0.7	
Length from hole center to component center	P2	6.35 Ref.		
Diameter of sprocket hole	Do	4±0.3		
Lead crimp height	H	18 ^{+1.5} ₋₁	16 ^{+1.5} ₋₁	
Lead spacing	F	2.5±0.8	5±0.8	
Top of component height	H1	26.5Max		

Dipped Radial Lead Type

● Capacitance Range

Style	Rate Voltage	NPO	X7R	X5R	Y5V	Z5U
R15AS2 R15AS5 R15DS5 R15DS6 R15DS7	6.3V			155 ~ 106	475 ~ 226	
	10V			334 ~ 475	225 ~ 106	
	16V		224 ~ 225	105	105 ~ 475	
	25V		104 ~ 155	224	474 ~ 225	
	50V	010 ~ 103	221 ~ 334		104 ~ 105	224 ~ 105
	100V	010 ~ 472	221 ~ 104			
	250V	101 ~ 272	102 ~ 333			
R18AS2 R18DS6 R18DS7	6.3V			106 ~ 226	476	
	10V			685 ~ 106	226	
	16V		335 ~ 475	106	106	
	25V		684 ~ 225	335	475	
	50V	392 ~ 333	474 ~ 105		225	
	100V	392 ~ 103	333 ~ 474			
	250V	332 ~ 822	153 ~ 154			
	500V	101 ~ 332	102 ~ 333			

Dipped Radial Lead Type

● Electrical Characteristics

NPO

Item	Temperature Compensating	Measuring Condition
Operating Temperature Range	-55 ~ +125°C	
Temperature Characteristics	0 ± 30 ppm/°C	
Capacitance	Within the specified tolerance	Shall be measured at 25°C± 2°C at the frequency and voltage
Q	C ≥ 30pF : Q ≥ 1000 C < 30pF : Q ≥ 400 + 20 × C (C is nominal capacitance)	C ≤ 1000pF@1MHz ± 20%, 1± 0.2Vrms C > 1000pF@1KHz ± 10%, 1± 0.2Vrms
Withstanding Voltage	No defects	Applied voltage : Rated voltage × 2.5 100V ~ 500V Rated voltage(over) × 1.5 Duration : 1 to 5 sec. The charge/discharge current is less than 50mA
Insulation Resistance	More than 10GΩ or 500MΩ·μF , whichever is less 16Vdc product : More than 10GΩ or 100MΩ·μF , whichever is less	Apply rated voltage for 1 minute at 25°C± 2°C and 70%R.H. max. . 16Vdc product : Measurement voltage is 25Vdc

Dipped Radial Lead Type

● Electrical Characteristics

X7R/X5R/Y5V/Z5U

Item	High Dielectric Constant		Measuring Condition
Operating Temperature Range	X7R = - 55 ~ +125°C X5R = - 55 ~ +85°C Y5V = - 30 ~ +85°C Z5U = +10 ~ +85°C		
Temperature Characteristics	X7R/X5R= ± 15% Y5V= +22 to - 82% Z5U= +22 to - 56%		
Capacitance	Within the specified tolerance		
Dissipation Factor (tanδ)	25V min	X7R=0.03max. X7R=0.055max. (C≥1.0uF) Y5V=0.075max. Z5U=0.09max.	Shall be measured at 25°C± 2°C at the frequency and voltage X7R/X5R/Y5V @1KHz ± 10%, 1± 0.2Vrms Z5U @1KHz ± 10%, 0.5± 0.2Vrms
		16V	
	10V max.	X7R/X5R=0.05max. Y5V=0.125max.	
	6.3V	X5R=0.075max.	
Withstanding Voltage	No defects		Applied voltage : Rated voltage ×2.5 100V ~ 500V Rated voltage(over) ×1.5 Duration : 1 to 5 sec. The charge/discharge current is less than 50mA
Insulation Resistance	More than 10GΩ or 500MΩ·μF , whichever is less. 16Vdc product : More than 10GΩ or 100MΩ·μF , whichever is less.		Apply rated voltage for 1 minute at 25°C± 2°C and 70%R.H. max. 16Vdc product : Measurement voltage is 25Vdc

UCC MONOLITHIC (MULTILAYER) CERAMIC CAPACITORS

UNIVERSE CONDENSER CO. LTD

Dipped Radial Lead Type

● Material List

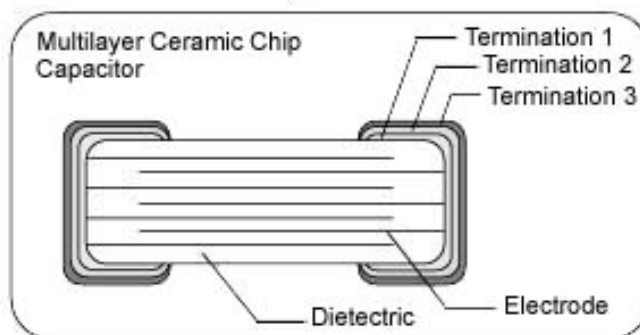
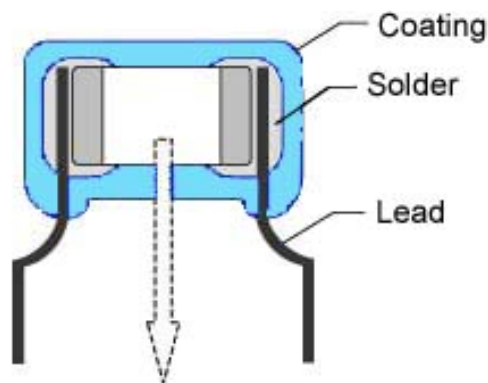

● Storage

1. The storage conditions should be:
 Temperature = Lower than 40°C
 Humidity = Lower than 70% R.H.
2. After opening the package, please store in desiccators.

● Environmental and Test Characteristics

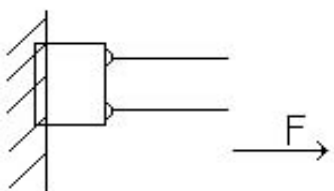
Item	Temperature Compensating	Measuring Condition
Strength of termination	Termination not to be broken or loosened Force : 2 LB min. Keep time : 10 ± 1 sec.	
Solderability of leads	Lead wire to be soldered vertically up to the coating end point. At least 75% of lead surface is covered	Solder temperature : 260 ± 5°C Dipping : 2 ± 0.5 sec. (containing Ag 2 ~ 5%) (Flux shall be used)

UNIVERSE CONDENSER CO. LTD. MONOLITHIC (MULTILAYER) CERAMIC CAPACITORS

UNIVERSE CONDENSER CO. LTD

Dipped Radial Lead Type

● Environmental and Test Characteristics

NPO

Item	Temperature Compensating	Measuring Condition															
<i>Resistance to Soldering heat</i>																	
ΔC	$\pm 2.5\%$ or $\pm 0.25\text{pF}$ (Whichever is greater)	The lead wire is immersed in the melted solder 1.5mm to 2mm from the main body at $260 \pm 5^\circ\text{C}$ for $10 \pm 0.5\text{sec.}$ Let sit at room temperature for $24 \pm 2\text{ hrs.}$ then measure. Perform the initial measurement.															
Q	$C \geq 30\text{pF} : Q \geq 1000$ $C < 30\text{pF} : Q \geq 400 + 20 \times C$ (C is nominal capacitance)																
I.R.	More than $10\text{G}\Omega$ or $500\text{M}\Omega \cdot \mu\text{F}$, whichever is less. 16Vdc product : More than $10\text{G}\Omega$ or $100\text{M}\Omega \cdot \mu\text{F}$, whichever is less.																
Withstanding voltage	No defects																
Exterior	No abnormalities																
<i>Thermal shock</i>																	
ΔC	$\pm 2.5\%$ or $\pm 0.25\text{pF}$ (Whichever is greater)	Fix the capacitor to the supporting jig in the same manner and under the same conditions as (10). Perform the five cycles according to the four heat treatments listed in the following table. Remove and let sit at room temperature for $24 \pm 2\text{ hrs.}$, then measure.															
Q	$C \geq 30\text{pF} : Q \geq 1000$ $C < 30\text{pF} : Q \geq 400 + 20 \times C$ (C is nominal capacitance)																
I.R.	More than $10\text{G}\Omega$ or $500\text{M}\Omega \cdot \mu\text{F}$, whichever is less. 16Vdc product : More than $10\text{G}\Omega$ or $100\text{M}\Omega \cdot \mu\text{F}$, whichever is less.																
Withstanding voltage	No defects																
Exterior	No abnormalities																
		<table border="1"> <thead> <tr> <th>Step</th> <th>1</th> <th>2</th> <th>3</th> <th>4</th> </tr> </thead> <tbody> <tr> <td>Temp. ($^\circ\text{C}$)</td> <td>Min. Operating Temp.</td> <td>Room Temp.</td> <td>Max. Operating Temp.</td> <td>Room Temp.</td> </tr> <tr> <td>Time</td> <td>30 ± 3</td> <td>15</td> <td>30 ± 3</td> <td>15</td> </tr> </tbody> </table>	Step	1	2	3	4	Temp. ($^\circ\text{C}$)	Min. Operating Temp.	Room Temp.	Max. Operating Temp.	Room Temp.	Time	30 ± 3	15	30 ± 3	15
Step	1	2	3	4													
Temp. ($^\circ\text{C}$)	Min. Operating Temp.	Room Temp.	Max. Operating Temp.	Room Temp.													
Time	30 ± 3	15	30 ± 3	15													
		Perform the initial measurement.															

Dipped Radial Lead Type

● Environmental and Test Characteristics

NPO

Item	Temperature Compensating	Measuring Condition
<i>Moisture resistance (Steady state)</i>		
ΔC	$\pm 5\%$ or $\pm 0.5\text{pF}$ (Whichever is greater)	Apply the rated DC voltage at $40 \pm 2^\circ\text{C}$ and 90 to 95% R.H. for 500_{-0}^{+24} hrs. Remove and let sit at room temperature for 24 ± 2 hrs., then measure. Perform the initial measurement.
Q	$C \geq 30\text{pF} : Q \geq 350$ $10\text{pF} > C < 30\text{pF} : Q \geq 275 + \frac{5}{2} \times C$ $C \leq 10\text{pF} : Q \geq 200 + 10 \times C$ (C is nominal capacitance)	
I.R.	More than $1000\text{M}\Omega$ or $50\text{M}\Omega \cdot \mu\text{F}$ whichever is less. 16Vdc product : More than $1000\text{M}\Omega$ or $10\text{M}\Omega \cdot \mu\text{F}$ whichever is less.	
Withstanding voltage	No defects	
Exterior	No abnormalities	
<i>High temperature loading</i>		
ΔC	$\pm 3\%$ or $\pm 0.3\text{pF}$ (Whichever is greater)	Apply 200% of the rated DC voltage for 1000_{-0}^{+48} hrs. at the maximum operating temperature $\pm 2^\circ\text{C}$. Remove and let sit at room temperature for 24 ± 2 hrs., then measure. The charge/discharge current is less than 50mA. Perform initial measurement. * 100% for 100V~500V over.
Q	$C \geq 30\text{pF} : Q \geq 350$ $10\text{pF} > C < 30\text{pF} : Q \geq 275 + \frac{5}{2} \times C$ $C \leq 10\text{pF} : Q \geq 200 + 10 \times C$ (C is nominal capacitance)	
I.R.	More than $1000\text{M}\Omega$ or $50\text{M}\Omega \cdot \mu\text{F}$ whichever is less. 16Vdc product : More than $1000\text{M}\Omega$ or $10\text{M}\Omega \cdot \mu\text{F}$ whichever is less.	
Withstanding voltage	No defects	
Exterior	No abnormalities	

UNIVERSE CONDENSER CO. LTD. MONOLITHIC (MULTILAYER) CERAMIC CAPACITORS

UNIVERSE CONDENSER CO. LTD

Dipped Radial Lead Type

● Environmental and Test Characteristics

X7R/X5R/Y5V/Z5U

Item	Temperature Compensating	Measuring Condition															
<i>Resistance to Soldering heat</i>																	
ΔC	X7R/X5R= $\pm 7.5\%$ Y5V= $\pm 20\%$ Z5U= $\pm 20\%$	<p>The lead wire is immersed in the melted solder 1.5mm to 2mm from the main body at $260 \pm 5^\circ\text{C}$ for $10 \pm 0.5\text{sec}$. Let sit at room temperature for 48 ± 4 hrs. , then measure.</p> <ul style="list-style-type: none"> Initial measurement for Perform a heat treatment at $150^{+0}_{-10}^\circ\text{C}$ for 1 hour. <p>Remove and let sit for 48 ± 4 hours at room temperature. Perform the initial measurement.</p>															
D.F.	<p>X7R=0.03max. 25V X7R=0.055max. ($C \geq 1.0\mu\text{F}$) min Y5V=0.075max Z5U=0.09max.</p>																
	<p>16V X7R/X5R=0.05max. Y5V=0.10max.</p>																
	<p>10V X7R/X5R=0.05max. max. Y5V=0.125max.</p>																
	<p>6.3V X5R=0.075max.</p>																
I.R.	<p>More than $10\text{G}\Omega$ or $500\text{M}\Omega \cdot \mu\text{F}$, whichever is less. 16Vdc product : More than $10\text{G}\Omega$ or $100\text{M}\Omega \cdot \mu\text{F}$, whichever is less.</p>																
Withstanding voltage	No defects																
Exterior	No abnormalities																
<i>Thermal shock</i>																	
ΔC	X7R/X5R= $\pm 7.5\%$ Y5V= $\pm 20\%$ Z5U= $\pm 30\%$	<p>Fix the capacitor to the supporting jig in the same manner and under the same conditions as (10). Perform the five cycles according to the four heat treatments listed in the following table. Remove and let sit at room temperature for 48 ± 4 hrs. , then measure.</p> <table border="1"> <thead> <tr> <th>Step</th> <th>1</th> <th>2</th> <th>3</th> <th>4</th> </tr> </thead> <tbody> <tr> <td>Temp. ($^\circ\text{C}$)</td> <td>Min. Operating Temp.</td> <td>Room Temp.</td> <td>Max. Operating Temp.</td> <td>Room Temp.</td> </tr> <tr> <td>Time</td> <td>30 ± 3</td> <td>15</td> <td>30 ± 3</td> <td>15</td> </tr> </tbody> </table> <ul style="list-style-type: none"> Initial measurement for Perform a heat treatment at $150^{+0}_{-10}^\circ\text{C}$ for 1 hour. <p>Remove and let sit for 48 ± 4 hrs. At room temperature. Perform the initial measurement.</p>	Step	1	2	3	4	Temp. ($^\circ\text{C}$)	Min. Operating Temp.	Room Temp.	Max. Operating Temp.	Room Temp.	Time	30 ± 3	15	30 ± 3	15
Step	1		2	3	4												
Temp. ($^\circ\text{C}$)	Min. Operating Temp.		Room Temp.	Max. Operating Temp.	Room Temp.												
Time	30 ± 3		15	30 ± 3	15												
D.F.	<p>X7R=0.03max. 25V X7R=0.055max. ($C \geq 1.0\mu\text{F}$) min Y5V=0.075max Z5U=0.09max.</p>																
	<p>16V X7R/X5R=0.05max. Y5V=0.10max.</p>																
	<p>10V X7R/X5R=0.05max. max. Y5V=0.125max.</p>																
	<p>6.3V X5R=0.075max.</p>																
I.R.	<p>More than $10\text{G}\Omega$ or $500\text{M}\Omega \cdot \mu\text{F}$, whichever is less. 16Vdc product : More than $10\text{G}\Omega$ or $100\text{M}\Omega \cdot \mu\text{F}$, whichever is less.</p>																
Withstanding voltage	No defects																
Exterior	No abnormalities.																

Dipped Radial Lead Type

● Environmental and Test Characteristics

X7R/X5R/Y5V/Z5U

Item	Temperature Compensating	Measuring Condition
<i>Moisture resistance (Steady state)</i>		
ΔC	X7R/X5R= $\pm 12.5\%$ Y5V= $\pm 30\%$ Z5U= $\pm 30\%$	Apply the rated DC voltage at 40 ± 2 °C and 90 to 95% R.H. for 500_{-0}^{+24} hrs. Remove and let sit at room temperature for 48 ± 4 hrs. , then measure. • Initial measurement for Perform a heat treatment at 150_{-10}^{+0} °C for 1 hour. Remove and let sit for 48 ± 4 hrs. At room temperature. Perform the initial measurement.
D.F.	X7R=0.06max. 25V X7R=0.11max. ($C \geq 1.0\mu F$) min Y5V=0.1125max. Z5U=0.135max.	
	16V X7R/X5R=0.10max. Y5V=0.15max.	
	10V X7R/X5R=0.10max. max. Y5V=0.1875max.	
	6.3V X5R=0.15max.	
I.R.	More than $1000M\Omega$ or $50M\Omega \cdot \mu F$, whichever is less. 16Vdc product : More than $1000M\Omega$ or $10M\Omega \cdot \mu F$, whichever is less.	
Withstanding voltage	No defects	
Exterior	No abnormalities	
<i>High temperature loading</i>		
ΔC	X7R/X5R= $\pm 15\%$ Y5V= $\pm 30\%$ Z5U= $\pm 30\%$	Apply 200% of the rated DC voltage for 1000_{-0}^{+48} hrs. at the maximum operating temperature ± 2 °C. Remove and let sit at room temperature for 48 ± 4 hrs. , then measure. The charge/discharge current is less than 50mA. • Initial measurement for Apply 200% of the rated DC voltage for 1 hour at the maximum operating temperature ± 2 °C . Remove and let sit at room temperature for 48 ± 4 hrs. Perform initial measurement. * 100% for 100V~500V
D.F.	X7R=0.06max. 25V X7R=0.11max. ($C \geq 1.0\mu F$) min Y5V=0.1125max. Z5U=0.135max.	
	16V X7R/X5R=0.10max. Y5V=0.15max.	
	10V X7R/X5R=0.10max. max. Y5V=0.1875max.	
	6.3V X5R=0.15max.	
I.R.	More than $1000M\Omega$ or $50M\Omega \cdot \mu F$, whichever is less. 16Vdc product : More than $1000M\Omega$ or $10M\Omega \cdot \mu F$, whichever is less.	
Withstanding voltage	No defects	
Exterior	No abnormalities	