

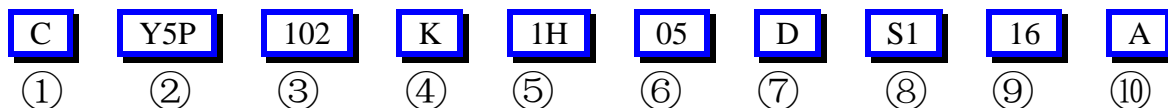

DISC CERAMIC CAPACITORS

UNIVERSE CONDENSER CO. LTD

1.0 Part Number Description



① Type

Symbol	Type
C	Resin Ceracoat
D	Epoxy Coated

② Temperature Characteristic

Temp. Charact.	Temperature Range	Capacitance Change
NPO	-25 ~ 85°C	0±60 ppm/°C
SL	-25 ~ 85°C	350 ~ -1000 ppm/°C
X7R	-55 ~ 125°C	±15%
Y5E	-25 ~ 85°C	±4.7%
Y5P	-25 ~ 85°C	±10%
Y5V	-25 ~ 85°C	+22%, -82%
Y5U	-25 ~ 85°C	+22%, -56%
Z5V	+10 ~ 85°C	+22%, -82%
Z5U	+10 ~ 85°C	+22%, -56%

③ Capacitance Value

Symbol	Capacitance Value
060	6pF
6R8	6.8pF
120	12pF
471	470pF
222	2200pF
104	100000pF

④ Capacitance Tolerance

Symbol	Capacitance Tolerance
C	±0.25pF
D	±0.5pF
F	±1%
G	±2%
J	±5%
K	±10%
M	±20%
Z	+80%, -20%

⑤ Rated Voltage

Symbol	Rated Voltage
1C	DC 16V
1E	DC 25V
1H	DC 50V
2A	DC 100V
2E	DC 250V
2H	DC 500V
2F	DC 630V
1K	DC 1000V
2K	DC 2000V
3K	DC 3000V
6K	DC 6000V
A1	AC 1000V
A2	AC 2000V



DISC CERAMIC CAPACITORS

UNIVERSE CONDENSER CO. LTD

⑥ External Dimensions (D) (mm)

Symbol	05	07	10	12
Φ	5 Φ	7 Φ	10 Φ	12 Φ

⑦ Lead Spacing (F) (mm)

Symbol	A	D	E	F	G
Spacing	2.5	5	6.35	7.52	10
Tol.	± 0.8				

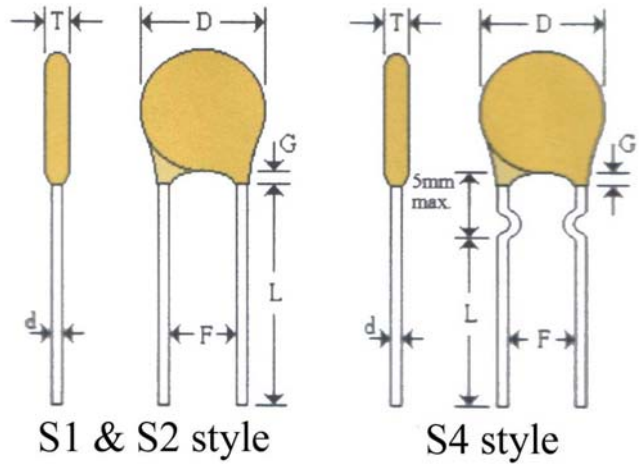

⑧ Lead Style

Symbol	S1 & S4 style	S2 style
d	0.6 \pm 0.05	0.5 \pm 0.05
F	Lead Spacing \rightarrow Refer 1.0	
L	Lead Length \rightarrow Refer 1.0	
D	Refer to Capacitance Range Chart	
T		
G		

Unit:mm

⑨ Lead Length (L) (mm)

Symbol	06	10	16	20	25	04
Length	6	10	16	20	25	3.5
Tol.	± 1	± 1	$+1.5$ -1	$+1.5$ -1	Min.	± 0.5

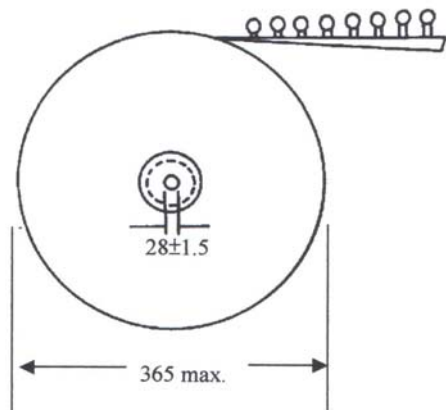
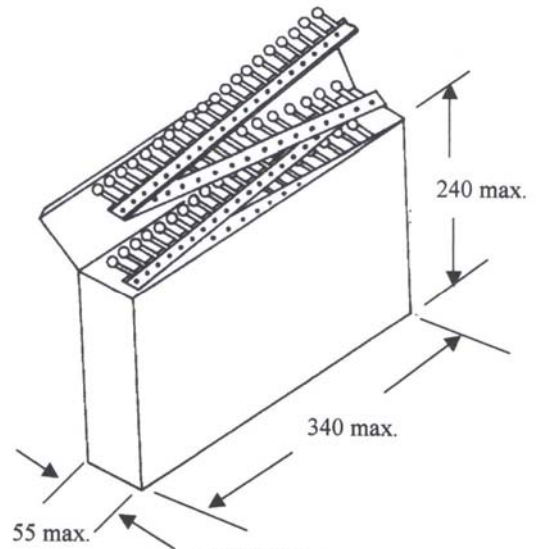

REEL type

⑩ Packing

Symbol	Quantity	
A	2000pcs Per AMMO	Taping type
R	2500pcs Per REEL	
No Code	1000pcs , 500pcs Per BAG	Bulk type



DISC CERAMIC CAPACITORS

UNIVERSE CONDENSER CO. LTD

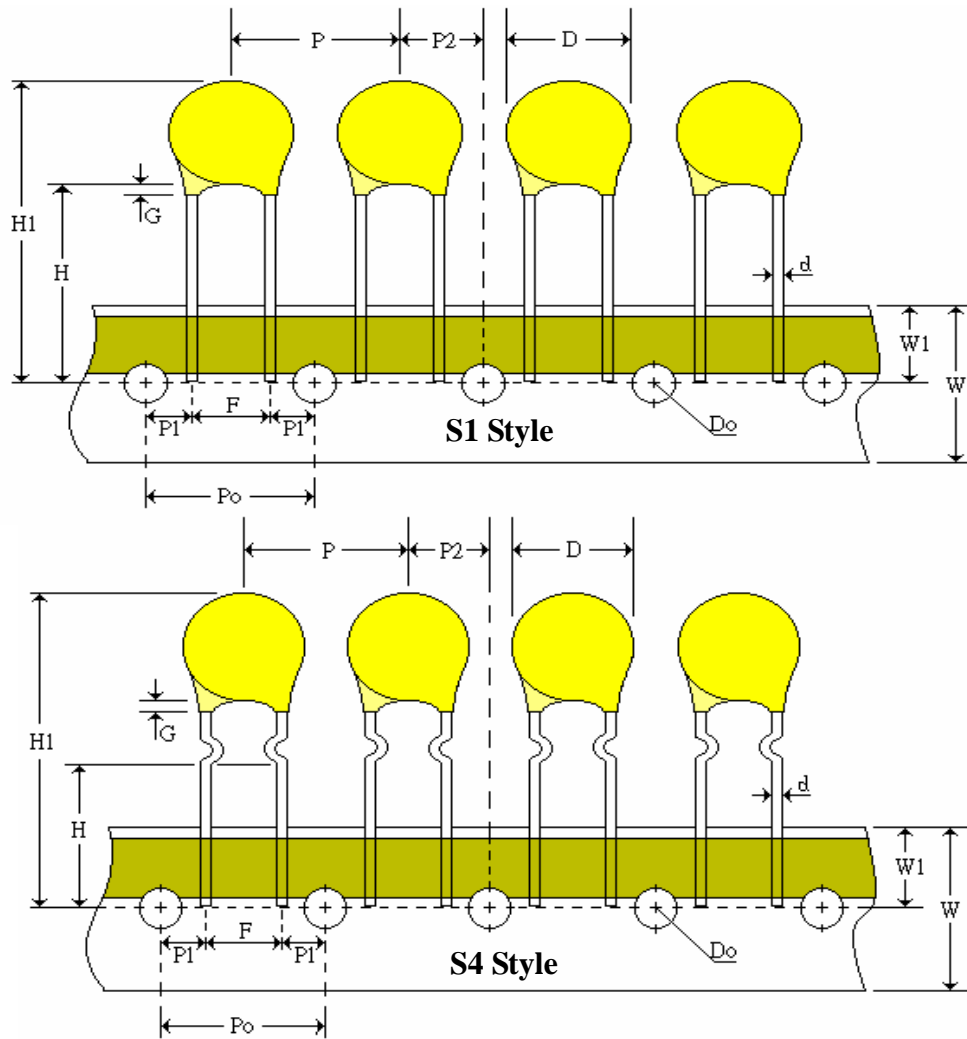

Description	Symbol	S1 style	S4 style	REMARK
Carrier Tape Width	W	18±0.5		
Position of Sprocket Hole	W1	9±0.5		
Pitch of Component	P	12.7 Ref.		
Pitch of Sprocket hole	Po	12.7±0.3		
Length from Hole Center to Lead	P1	5.1±0.7	3.85±0.7	P1=3.18±0.7 refer to F=6.35±0.8
		3.85±0.7		
		3.18±0.7		
Length from Hole Center to Component Center	P2	6.35 Ref.		
Diameter of Sprocket Hole	Do	4±0.3		
Diameter of Body	D			Refer Capacitance Range Chart
Diameter of Lead Wire	D	0.6±0.05		
Lead Spacing	F	2.5±0.8	5±0.8	
		5±0.8		
		6.35±0.8		
Lead Crimped Height	H	16	16	Tolerance ^{+1.5} ₋₁
		20		
Top of Component Height	H1	32.25max.		
Coating extension on Lead	G			Refer Capacitance Range Chart
Thickness of Body	T			Refer Capacitance Range Chart



DISC CERAMIC CAPACITORS

UNIVERSE CONDENSER CO. LTD

2.0 Capacitance Range Chart (Class I 、 II)

(Max. Capacitance in pF)

W.Vdc	NPO (CH)	SL	X7R	B (Y5E) (Y5P)	E (Z5U)	F (Z5V)	Dimensions (mm)		
							D	T	G
50V 100V	0.5~47	33~150	220	100~2200	1000~5000	3300~10000	5±1	<3.5	<1.5
	50~68	180~220	2200	3300	5600~6800		6±1	<3.5	<1.5
	75~100	250~330		3900	7500~10000	12000~22000	7±1	<3.5	<1.5
	120~150	390		4700~6800			8±1	<3.5	<1.5
	180~200	470~560					9±1	<3.5	<1.5
	220~270	680~820			7500~10000		10±1	<3.5	<1.5
	300~330						12±1	<3.5	<1.5

耐壓 100Vdc 以下，均需符合 Coating 之可漏底不漏銀電極的製作規範。

(Max. Capacitance in pF)

W.Vdc	NPO (CH)	SL	X7R	B (Y5E) (Y5P)	E (Z5U)	F (Z5V)	Dimensions (mm)		
							D	T	G
500V 630V	0.5~15	22~68	220~470	100~1000	1000~1200		5±1	<3.8	<2.0
	18~33	82~120	680~1000	1200~1500	1500~2200	3300~5000	6±1	<3.8	<2.0
	39~56	150~220	1500~2200	1800~2200	2700~4700	5600~6800	7±1	<3.8	<2.0
	68~82	270~330		2700~3000	5600~6800	8200~10000	8±1	<3.8	<2.0
	100~120	390~470		3300~3900	8200~10000		9±1	<3.8	<2.0
	150~180		4700	4700~5000			10±1	<3.8	<2.0
	200~220			5600~6800	12000~15000	15000~22000	12±1	<3.8	<2.0
				8200~10000	18000~22000	27000~47000	14±1	<3.8	<2.0
						100000	16±1	<3.8	<2.0

3.0 Semi-Conductive Capacitance Range Chart (Class III)

(Max. Capacitance in pF)

W.Vdc	E (Y5U)	F (Y5V)	Dimensions (mm)		
			D	T	G
12V 16V	100000	100000	6±1	<3	<1.5
			8±1	<3	<1.5
25V	10000	10000~22000	3.5±1	<3	<1.5
	47000		5±1	<3	<1.5
	100000	100000	6±1	<3	<1.5
			7±1	<3	<1.5
50V	10000	10000~22000	3.5±1	<3	<1.5
	22000	47000	4.5±1	<3	<1.5
	33000~47000		5±1	<3	<1.5
	100000	100000	6±1	<3	<1.5
			8±1	<3	<1.5

耐壓 100Vdc 以下，均需符合 Coating 之可漏底不漏銀電極的製作規範。



DISC CERAMIC CAPACITORS

UNIVERSE CONDENSER CO. LTD

4.0 Medium-High Voltage Capacitance Range Chart (Class I、II)

耐壓 1KVdc 以上，均需符合 Coating 之不可漏底的製作規範。

(Max. Capacitance in pF)

W.Vdc	NPO (CH)	SL	X7R	B (Y5E) (Y5P)	E (Z5U)	F (Z5V)	Dimensions (mm)		
							D	T	G
1KV	1~10	30~56	180~470	100~470	1000~1200		5±1	<3.8	<2.0
	12~33	68~100	100,680~1000	500~680	1500~2200		6±1	<3.8	<2.0
	39~51	120~150		820~1000	2700~3300		7±1	<3.8	<2.0
	56~68	1800~220	1500	1500~1800	3900	4700~6800	8±1	<3.8	<2.0
	75~91	270~330	2200	2000~2200	4700~5600	8200~10000	9±1	<3.8	<2.0
	100~120	390	3300	2700~3300	6800,10000	12000	10±1	<3.8	<2.0
					8200~10000	15000	11±1	<3.8	<2.0
	150~180	470~560	4700	3900~4700	10000~12000		12±1	<3.8	<2.0
200~220	680~820		5000~6800	15000	18000~22000	14±1	<3.8	<2.0	

W.Vdc	NPO (CH)	SL	X7R	B (Y5E) (Y5P)	E (Z5U)	F (Z5V)	Dimensions (mm)		
							D	T	G
2KV	1~20	15~56		100~470	1000~1200		5±1.5	<4.5	<2.0
	22~30	68~100		560~820	1500~2200	3300~3900	6±1.5	<4.5	<2.0
	33~39	120~150	1000	1000~1200	2700~3300	4700~5100	7±1.5	<4.5	<2.0
	47~51	180		1500	3900	5600~6800	8±1.5	<4.5	<2.0
	56~68	200~220		1800~2000		8200	9±1.5	<4.5	<2.0
	75~82	270~300		2200~2700	4700~5600	10000	10±1.5	<4.5	<2.0
	90~100	330		3000~3300		12000	11±1.5	<4.5	<2.0
	110~120			3900	6800		12±1.5	<4.5	<2.0
	150	390					13±1.5	<4.5	<2.0
			4700~5600	8200~10000		14±1.5	<4.5	<2.0	

W.Vdc	NPO (CH)	SL	B (Y5E) (Y5P)	E (Z5U)	F (Z5V)	Dimensions (mm)		
						D	T	G
3KV	1~18	15~47	100~470	1000~1200	1800~2200	7±1.5	<4.5	<3.0
	20~30	50~680	680~820	1500	2700~3300	8±1.5	<4.5	<3.0
	33~39	82~100	1000	1800~2000	3900	9±1.5	<4.5	<3.0
	47~56	120	1200	2200~2700	4700~5600	10±1.5	<4.5	<3.0
	62~68	150~180	1500	3000~3300		11±1.5	<4.5	<3.0
	72~82	200~220	1800		6800~8200	12±1.5	<4.5	<3.0
		270	2000~2200	3900~4700		13±1.5	<4.5	<3.0
		300~330			10000	14±1.5	<4.5	<3.0
		2700~3300	5000~6800		15±1.5	<4.5	<3.0	



DISC CERAMIC CAPACITORS

UNIVERSE CONDENSER CO. LTD

(Max. Capacitance in pF)

W.Vdc	SL	B (Y5P)	E (Z5U)	Dimensions (mm)		
				D	T	G
6KV		100~330		6±1.5		
	5~39	390~510		7±1.5		
	47~56	560~680	1000	8±1.5		
	68			9±1.5		
	82	820	1500	10±1.5		
			2200	11±1.5		
	100~120	1000		12±1.5		
		1500		13±1.5		
	150		3300	14±1.5		
			15±1.5			



DISC CERAMIC CAPACITORS

UNIVERSE CONDENSER CO. LTD

5.0 Specification

No	Item	Class I	Class II	Class III	Measuring Condition															
1	Visual and mechanical examination	To be within the specifications shows in			Capacitors shall be visually inspected for visible evidence of defect. Dimensions shall be measured with calipers or micrometers. Marking shall be legibility.															
2	Operating Temperature Range	- 25°C to +85°C	Y5E 、 Y5P : - 25°C to +85°C Z5U 、 Z5V : +10°C to +85°C X7R : - 55°C to +125°C	Y5V & Y5U & Y5P : - 25°C to +85°C	Class III is semi-conductor material															
3	Temperature Characteristics	NPO(CH) : 0 ± 60ppm/°C PH : - 150 ± 60ppm/°C RH : - 220 ± 60ppm/°C SH : - 330 ± 60ppm/°C TH : - 470 ± 60ppm/°C UJ : - 750 ± 120ppm/°C SL : +350 to- 1000ppm/°C	Y5E : ± 4.7% Y5P : ± 10% Z5U : +22 -56 % Z5V : +22 -82 % X7R : ± 15%	Y5U : +22 -56 % Y5V : +22 -82 % Y5P : ±10 %	Retain the sample for 30 minutes at the temperature specified below in the sequence listed in the table. Then measure the capacitance in each step after thermal equilibrium at each temperature is reached. <table border="1"> <thead> <tr> <th>Step 1</th> <th>Step 2</th> <th>Step 3</th> <th>Step 4</th> <th>Step 5</th> </tr> </thead> <tbody> <tr> <td>Room Temp.</td> <td>Min. Operating Temp.</td> <td>Room Temp.</td> <td>Max. Operating Temp.</td> <td>Room Temp.</td> </tr> <tr> <td>25±2°C</td> <td>-25±3°C 10±2°C</td> <td>25±2°C</td> <td>85±2°C</td> <td>25±2°C</td> </tr> </tbody> </table> Note that step 1 and 2 do not apply for the SL characteristics.	Step 1	Step 2	Step 3	Step 4	Step 5	Room Temp.	Min. Operating Temp.	Room Temp.	Max. Operating Temp.	Room Temp.	25±2°C	-25±3°C 10±2°C	25±2°C	85±2°C	25±2°C
Step 1	Step 2	Step 3	Step 4	Step 5																
Room Temp.	Min. Operating Temp.	Room Temp.	Max. Operating Temp.	Room Temp.																
25±2°C	-25±3°C 10±2°C	25±2°C	85±2°C	25±2°C																
4	Capacitance	To be within the specified tolerance			Shall be measured at 25°C ± 2°C normal temperature at the frequency and voltage															
5	Q or Dissipation Factor (tan δ)	C ≥ 30pF : Q ≥ 1000 C < 30pF : Q ≥ 400 + 20 × C (C is nominal capacitance)	Y5E & Y5P & Z5U & X7R : tan δ ≤ 0.025 Z5V : tan δ ≤ 0.05	Y5U & Y5V & Y5P : tan δ ≤ 0.05	Class I : 1MHz ± 20% , 1 ± 0.2Vrms Class II : 1KHz ± 10% , 1 ± 0.2Vrms Class III : 1KHz ± 10% , 0.5 ± 0.05Vrms															
6	Withstanding Voltage	No defects			Applied voltage : Rated voltage ×3 (Class I) Rated voltage ×2.5 (Class II) Rated voltage ×2 (Class III) Duration : 1 to 5 sec. The charge/discharge current is less than 50mA															
7	Insulation Resistance	More than 10GΩ	More than 10GΩ or 200MΩ • F, whichever is less.	More than 1GΩ or 20MΩ • F, whichever is less.	Apply rated voltage for 1 minute at 25°C ± 2°C and 70% R.H. max. 16Vdc product : Measurement voltage is 25Vdc															
8	Strength of Lead	Termination not to be broken or loosened			Fix the capacitor, apply the tensile stress listed below in the terminal extraction direction until the designated value is reached, then retain the capacitor for 10 ± 1 seconds as is. <table border="1"> <tbody> <tr> <td>Nominal wire diameter</td> <td>0.5mm</td> <td>0.6mm</td> </tr> <tr> <td>Tensile stress</td> <td>1kg</td> <td>1.5kg</td> </tr> </tbody> </table>	Nominal wire diameter	0.5mm	0.6mm	Tensile stress	1kg	1.5kg									
Nominal wire diameter	0.5mm	0.6mm																		
Tensile stress	1kg	1.5kg																		
9	Solderability of leads	At least 75% of the immersed surface in the circumference direction is covered with new solder.			Solder temperature : Class I : 260 ± 5°C Class II、 III : 250 ± 5°C Dipping : 3 ± 0.5 sec. (Flux shall be used)															



DISC CERAMIC CAPACITORS

UNIVERSE CONDENSER CO. LTD

5.0 Specification

No	Item	Class I	Class II	Class III	Measuring Condition																
10	Resistance to Soldering heat	ΔC	$\pm 2.5\%$ or $\pm 0.25pF$ (Whichever is greater)	Y5E 、 Y5P : $\pm 5\%$ X7R : $\pm 7.5\%$ Z5U : $\pm 15\%$ Z5V : $\pm 20\%$	Y5U & Y5V : $\pm 30\%$ Y5P : $\pm 7.5\%$	The lead wire is immersed in the melted solder 1.5mm to 2mm from the capacitor body (Class I, II) Solder temperature : $350 \pm 10^\circ C$ Duration : $3 \pm 0.5sec.$ (Class III) Solder temperature : $260 \pm 5^\circ C$ Duration : $5 \pm 0.5sec.$ The measurements after testing must be taken after leaving the sample for 12 to 24 hours under normal temperature and humidity conditions.															
		Withstanding voltage	No defects																		
		Exterior	No abnormalities																		
11	Temperature and Immersion cycling	ΔC	$\pm 5\%$ or $\pm 0.5pF$ (Whichever is greater)	Y5E 、 Y5P : $\pm 10\%$ X7R : $\pm 15\%$ Z5U : $\pm 20\%$ Z5V : $\pm 30\%$	Y5U & Y5V : $\pm 30\%$ Y5P : $\pm 15\%$	Fix the capacitor to the supporting jig in the same manner and under the same conditions as (10). Perform the 5 cycles according to the four heat treatments listed in the following table. <table border="1" style="margin: 5px auto;"> <thead> <tr> <th>Step</th> <th>1</th> <th>2</th> <th>3</th> <th>4</th> </tr> </thead> <tbody> <tr> <td>Temp. ($^\circ C$)</td> <td>Min. Operating Temp.</td> <td>Room Temp.</td> <td>Max. Operating Temp.</td> <td>Room Temp.</td> </tr> <tr> <td>Time (min.)</td> <td>30 ± 3</td> <td>15</td> <td>30 ± 3</td> <td>15</td> </tr> </tbody> </table> The measurements after testing must be taken after leaving the sample for 12 to 24 hours under normal temperature and humidity conditions.	Step	1	2	3	4	Temp. ($^\circ C$)	Min. Operating Temp.	Room Temp.	Max. Operating Temp.	Room Temp.	Time (min.)	30 ± 3	15	30 ± 3	15
		Step	1	2	3		4														
		Temp. ($^\circ C$)	Min. Operating Temp.	Room Temp.	Max. Operating Temp.		Room Temp.														
		Time (min.)	30 ± 3	15	30 ± 3		15														
		Q/D.F.	$C \geq 30pF$: $Q \geq 350$ $10pF > C < 30pF$: $Q \geq 275 + \frac{5}{2} \times C$ $C \leq 10pF$: $Q \geq 200 + 10 \times C$ (C is nominal capacitance)	Y5E & Y5P & Z5U & X7R : $\tan \delta \leq 0.05$ Z5V : $\tan \delta \leq 0.075$	Y5U & Y5P : $\tan \delta \leq 0.05$ Y5V : $\tan \delta \leq 0.075$																
I.R.	More than $1G\Omega$	More than $1G\Omega$ or $20M\Omega \cdot F$, whichever is less.	More than $500M\Omega$ or $10M\Omega \cdot F$, whichever is less.																		
Withstanding voltage	No defects																				
Exterior	No abnormalities																				
12	Humidity Loading	ΔC	$\pm 7.5\%$ or $\pm 0.75pF$ (Whichever is greater)	Y5E 、 Y5P : $\pm 10\%$ X7R : $\pm 15\%$ Z5U : $\pm 20\%$ Z5V : $\pm 30\%$	Y5U & Y5V : $\pm 30\%$ Y5P : $\pm 15\%$	Temperature : $40 \pm 2^\circ C$ Humidity : 90 to 95% R.H. Duration : 500^{+24}_{-0} hrs. The rated voltage continuously applied. The charge/discharge current is less than 10mA. The measurements after testing must be taken after leaving the sample for 1 to 2 hours under normal temperature and humidity conditions. • Perform a heat treatment at $40 \pm 2^\circ C$ for 1 hour. Remove and let sit for 1 to 2 hours at normal temperature and humidity conditions. Perform the initial measurement.															
		Q/D.F.	$C \geq 30pF$: $Q \geq 200$ $C < 30pF$: $Q \geq 100 + \frac{10}{3} \times C$ (C is nominal capacitance)	Y5E & Y5P & Z5U & X7R : $\tan \delta \leq 0.05$ Z5V : $\tan \delta \leq 0.075$	Y5U & Y5V & Y5P : $\tan \delta \leq 0.075$																
		I.R.	More than $1G\Omega$	More than $1G\Omega$ or $20M\Omega \cdot F$, whichever is less.	More than $500M\Omega$ or $10M\Omega \cdot F$, whichever is less.																
		Withstanding voltage	No defects																		
		Exterior	No abnormalities																		



DISC CERAMIC CAPACITORS

UNIVERSE CONDENSER CO. LTD

5.0 Specification

No	Item	Class I	Class II	Class III	Measuring Condition	
13	Life	ΔC	± 5% or ± 0.5pF (Whichever is greater)	Y5E · Y5P : ± 10% X7R : ± 15% Z5U : ± 20% Z5V : ± 30%	Y5U & Y5V : ± 30% Y5P : ± 15 %	Applied voltage : Rated voltage ×2(Class I, II) Rated voltage ×1.25(Class III) Temperature : 85± 2°C Duration : 1000 ⁺⁴⁸ ₋₀ hrs. The charge/discharge current is less than 10mA. The measurements after testing must be taken after leaving the sample for 12 to 24 hours under normal temperature and humidity conditions. • Perform a heat treatment at 85± 2°C for 1 hour. Remove and let sit for 12 to 24 hours at normal temperature and humidity conditions. Perform the initial measurement.
		Q/D.F.	$C \geq 30\text{pF} : Q \geq 350$ $10\text{pF} < C < 30\text{pF} :$ $Q \geq 275 + \frac{5}{2} \times C$ $C \leq 10\text{pF} : Q \geq 200 + 10 \times C$ (C is nominal capacitance)	Y5E & Y5P & Z5U & X7R : $\tan \delta \leq 0.05$ Z5V : $\tan \delta \leq 0.075$	Y5U & Y5V & Y5P : $\tan \delta \leq 0.075$	
		I.R.	More than 1GΩ	More than 1GΩ or 20MΩ · F, whichever is less.	More than 500MΩ or 10MΩ · F, whichever is less.	
		Withstanding voltage	No defects			
		Exterior	No abnormalities			

* Note on standard condition : “standard condition” referred to herein is defined as follows :

5 to 35°C of temperature, 45 to 85% relative humidity, and 860 to 1060 mbar of air pressure.

When there are questions concerning measurement results :

In order to provide correlation data, the test shall be conducted under condition of 23°C ± 2°C of temperature, 60 to 70% relative humidity, and 860 to 1060 mbar of air

Pressure, Unless otherwise specified, all the tests are conducted under the “standard condition” .

6.0 Storage

1. The storage conditions should be:

Temperature = Lower than 40°C

Humidity = Lower than 70% R.H.

2. After opening the package, please store in desiccators.



DISC CERAMIC CAPACITORS

UNIVERSE CONDENSER CO. LTD

Medium-High Voltage Capacitor

7.0 Specification

No	Item	Class I	Class II	Measuring Condition															
1	Visual and mechanical examination	To be within the specifications shows in		Capacitors shall be visually inspected for visible evidence of defect. Dimensions shall be measured with calipers or micrometers. Marking shall be legibility.															
2	Operating Temperature Range	NPO、SL : - 25°C to +85°C	Y5E、Y5P : - 25°C to +85°C X7R : - 55°C to +125°C Z5U、Z5V : +10°C to +85°C																
3	Temperature Characteristics	NPO(CH) : 0 ± 60ppm/°C UJ : - 750 ± 120ppm/°C SL : +350 to- 1000ppm/°C	Y5E : ± 4.7% Y5P : ± 10% X7R : ± 15% Z5U : +22 / -56 % Z5V : +22 / -82 %	Retain the sample for 30 minutes at the temperature specified below in the sequence listed in the table. Then measure the capacitance in each step after thermal equilibrium at each temperature is reached. <table border="1"> <thead> <tr> <th>Step 1</th> <th>Step 2</th> <th>Step 3</th> <th>Step 4</th> <th>Step 5</th> </tr> <tr> <th>Room Temp.</th> <th>Min. Operating Temp.</th> <th>Room Temp.</th> <th>Max. Operating Temp.</th> <th>Room Temp.</th> </tr> </thead> <tbody> <tr> <td>25±2°C</td> <td>-25±3°C 10±2°C</td> <td>25±2°C</td> <td>85±2°C</td> <td>25±2°C</td> </tr> </tbody> </table> Note that step 1 and 2 do not apply for the SL characteristics.	Step 1	Step 2	Step 3	Step 4	Step 5	Room Temp.	Min. Operating Temp.	Room Temp.	Max. Operating Temp.	Room Temp.	25±2°C	-25±3°C 10±2°C	25±2°C	85±2°C	25±2°C
Step 1	Step 2	Step 3	Step 4	Step 5															
Room Temp.	Min. Operating Temp.	Room Temp.	Max. Operating Temp.	Room Temp.															
25±2°C	-25±3°C 10±2°C	25±2°C	85±2°C	25±2°C															
4	Capacitance	To be within the specified tolerance		Shall be measured at 25°C ± 2°C normal temperature at the frequency and voltage															
5	Q or Dissipation Factor (tan δ)	C ≥ 30pF : Q ≥ 1000 C < 30pF : Q ≥ 400 + 20 × C (C is nominal capacitance)	Y5E & Y5P & X7R & Z5U : tan δ ≤ 0.025 Z5V : tan δ ≤ 0.05	Class I : 1MHz ± 20% , 1 ± 0.2Vrms Class II : 1KHz ± 10% , 1 ± 0.2Vrms															
6	Withstanding Voltage	No defects between terminals No defects between terminal and body		Applied voltage : Rated voltage × 2 (Class I) Rated voltage × 1.5 (Class II) Rated voltage : AC4.5KV (Class I :6KV) Duration : 1 to 5 sec. The charge/discharge current is less than 50mA Applied voltage : 1.3kVdc Duration : 1 to 5 sec.															
7	Insulation Resistance	More than 10GΩ or 200MΩ · F , whichever is less.		Apply 500Vdc for 1 minute at 25°C ± 2°C and 70% R.H. max.															
8	Strength of Lead	Termination not to be broken or loosened		Fix the capacitor, apply the tensile stress listed below in the terminal extraction direction until the designated value is reached, then retain the capacitor for 10 ± 1 seconds as is. Tensile stress ≥ 1.5kg															
9	Solderability of leads	At least three-fourths of the immersed surface in the circumference direction is covered with new solder.		Solder temperature : Class I : 260 ± 5°C Class II : 250 ± 5°C Dipping : 2 ± 0.5 sec. (Flux shall be used)															



DISC CERAMIC CAPACITORS

UNIVERSE CONDENSER CO. LTD

Medium-High Voltage Capacitor

7.0 Specification

No	Item	Class I	Class II	Measuring Condition																
10	Resistance to Soldering heat	ΔC	$\pm 2.5\%$ or $\pm 0.25\text{pF}$ (Whichever is greater)	Y5E & Y5P : $\pm 5\%$ X7R : $\pm 7.5\%$ Z5U : $\pm 15\%$ Z5V : $\pm 20\%$	The lead wire is immersed in the melted solder 1.5mm to 2mm from the capacitor body (Class I, II) Solder temperature : $260 \pm 5^\circ\text{C}$ Duration : $5 \pm 0.5\text{sec.}$ The measurements after testing must be taken after leaving the sample for 12 to 24 hours under normal temperature and humidity conditions.															
		Withstanding voltage	No defects																	
		Exterior	No abnormalities																	
11	Temperature and Immersion cycling	ΔC	$\pm 5\%$ or $\pm 0.5\text{pF}$ (Whichever is greater)	Y5E & Y5P : $\pm 10\%$ X7R : $\pm 12.5\%$ Z5U : $\pm 20\%$ Z5V : $\pm 30\%$	Fix the capacitor to the supporting jig in the same manner and under the same conditions as (10). Perform the five cycles according to the four heat treatments listed in the following table. <table border="1" style="margin: 10px auto;"> <thead> <tr> <th>Step</th> <th>1</th> <th>2</th> <th>3</th> <th>4</th> </tr> </thead> <tbody> <tr> <td>Temp. (°C)</td> <td>Min. Operating Temp.</td> <td>Room Temp.</td> <td>Max. Operating Temp.</td> <td>Room Temp.</td> </tr> <tr> <td>Time (min.)</td> <td>30±3</td> <td>15</td> <td>30±3</td> <td>15</td> </tr> </tbody> </table> The measurements after testing must be taken after leaving the sample for 12 to 24 hours under normal temperature and humidity conditions.	Step	1	2	3	4	Temp. (°C)	Min. Operating Temp.	Room Temp.	Max. Operating Temp.	Room Temp.	Time (min.)	30±3	15	30±3	15
		Step	1	2		3	4													
		Temp. (°C)	Min. Operating Temp.	Room Temp.		Max. Operating Temp.	Room Temp.													
		Time (min.)	30±3	15		30±3	15													
		Q/D.F.	$C \geq 30\text{pF} : Q \geq 350$ $10\text{pF} > C < 30\text{pF} :$ $Q \geq 275 + \frac{5}{2} \times C$ $C \leq 10\text{pF} : Q \geq 200 + 10 \times$	X7R : $\tan \delta \leq 0.04$ Y5E & Y5P & Z5U : $\tan \delta \leq 0.05$ Z5V : $\tan \delta \leq 0.075$																
I.R.	More than $1\text{G}\Omega$	More than $1\text{G}\Omega$ or $20\text{M}\Omega \cdot \text{F}$, whichever is less.																		
Withstanding voltage	No defects																			
Exterior	No abnormalities																			
12	Humidity Loading	ΔC	$\pm 7.5\%$ or $\pm 0.75\text{pF}$ (Whichever is greater)	Y5E & Y5P : $\pm 10\%$ X7R : $\pm 12.5\%$ Z5U : $\pm 20\%$ Z5V : $\pm 30\%$	Temperature : $40 \pm 2^\circ\text{C}$ Humidity : 90 to 95% R.H. Duration : 500^{+24}_{-0} hrs. The rated voltage continuously applied. The charge/discharge current is less than 10mA. The measurements after testing must be taken after leaving the sample for 1 to 2 hours under normal temperature and humidity conditions. • Perform a heat treatment at $40 \pm 2^\circ\text{C}$ for 1 hour. Remove and let sit for 1 to 2 hours at normal temperature and humidity conditions. Perform the initial measurement.															
		Q/D.F.	$C \geq 30\text{pF} : Q \geq 200$ $C < 30\text{pF} :$ $Q \geq 100 + \frac{10}{3} \times C$ (C is nominal capacitance)	X7R : $\tan \delta \leq 0.04$ Y5E & Y5P & Z5U : $\tan \delta \leq 0.05$ Z5V : $\tan \delta \leq 0.075$																
		I.R.	More than $500\text{M}\Omega$																	
		Withstanding voltage	No defects																	
		Exterior	No abnormalities																	



DISC CERAMIC CAPACITORS

UNIVERSE CONDENSER CO. LTD

Medium-High Voltage Capacitor

7.0 Specification

No	Item	Class I	Class II	Measuring Condition	
13	Life	ΔC	$\pm 5\%$ or $\pm 0.5\text{pF}$ (Whichever is greater)	Y5E 、 Y5P : $\pm 10\%$ X7R : $\pm 12.5\%$ Z5U : $\pm 20\%$ Z5V : $\pm 30\%$	Applied voltage : Rated voltage $\times 1.5$ (Class I) Rated voltage $\times 1.25$ (Class II) Temperature : $85 \pm 2^\circ\text{C}$ Duration : 1000^{+48}_{-0} hrs. The charge/discharge current is less than 10mA. The measurements after testing must be taken after leaving the sample for 12 to 24 hours under normal temperature and humidity conditions. • Perform a heat treatment at $85 \pm 2^\circ\text{C}$ for 1 hour. Remove and let sit for 12 to 24 hours at normal temperature and humidity conditions. Perform the initial measurement.
		Q/D.F.	$C \geq 30\text{pF} : Q \geq 350$ $10\text{pF} > C < 30\text{pF} :$ $Q \geq 275 + \frac{5}{2} \times C$ $C \leq 10\text{pF} : Q \geq 200 + 10 \times C$ (C is nominal capacitance)	X7R : $\tan \delta \leq 0.04$ Y5E 、 Y5P 、 Z5U : $\tan \delta \leq 0.05$ Z5V : $\tan \delta \leq 0.075$	
		I.R.	More than $1\text{G}\Omega$	More than $1\text{G}\Omega$ or $20\text{M}\Omega \cdot \text{F}$, whichever is less.	
		Withstanding voltage	No defects		
		Exterior	No abnormalities		