

OUTLINE OF CHANGES ON THE DOCUMENT				
Version	Description	Page of modification	Issue by	Issue date
A	First released	-	Amy	2008.05.07

## SPECIFICATION FOR ROTARY ENCODER

ATTENTION	
<p><i>Customer shall acknowledge the datasheet by returning "this cover page with authorized signature" before placing order. Lack of acknowledgement or additional response constitutes acceptance of the herein contents.</i></p> <p>下單前請將此份"規格書封面簽回",未簽回則視為承認本規格書內容.</p>	
<b>Approved By</b>	<b>Entered Date</b>

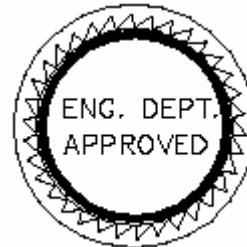

**CUSTOMER:** \_\_\_\_\_

**PART NO.:** \_\_\_\_\_

**TAIWAY P/N:** 841-A100  
841-B100

**DATE OF ISSUE:** 2008 May 07

**ISSUE BY:** Amy Yen

**APPROVED BY:** Amy Yen

# TAIWAY ELECTRONICS COMPONENTS CO., LTD.

## 841 SERIES SPECIFICATION

**File No.:**









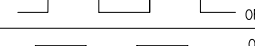

**841**

**Rev.: A**

**Page: 5 pages**

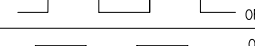
### General

Test condition: The standard test shall be 5 ~ 35°C temperature and 45 ~ 85% relative humidity. 86 ~ 106kPa atmospheric pressure unless otherwise specified. In case of any question happen. Retest condition shall specify by temperature 20±2°C, 60~70%RH and 86 ~ 106kPa.

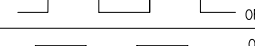
<b>ELECTRICAL CHARACTERISTICS</b>	<b>CONTACT RATING:</b>	5VDC, 0.5mA (terminal A and B) 1.0mA (terminal C)													
	<b>ELECTRICAL LIFE:</b>	The shaft shall be rotated at no load for a total of 20,000± 1000 cycles, whereas 1 cycle is 360° rotation													
	<b>INSULATION RESISTANCE:</b>	To be measured with an insulation measuring device of 50VDC between all the terminals and between the terminals and the body for 1 minute ±5 seconds. Min. 10M-ohms													
	<b>DIELECTRICAL STRENGTH:</b>	AC 50V (50~60Hz 2mA current) being applied between all the terminals and between the terminal and the body for 1 minute. There shall be no flashover													
	<b>OPERATING TEMPERATURE:</b>	-10celsius degree to +70celsius degree													
	<b>STORAGE TEMPERATURE:</b>	-25celsius degree to +70celsius degree													
	<b>OUTPUT SIGNAL:</b>	<table border="1" style="margin: auto; border-collapse: collapse;"> <thead> <tr> <th style="font-size: small;">Rotational direction</th> <th style="font-size: small;">Signal</th> <th style="font-size: small;">Output</th> </tr> </thead> <tbody> <tr> <td rowspan="2" style="text-align: center; vertical-align: middle;">C.W.</td> <td style="text-align: center;">⊙ - ⊕</td> <td style="text-align: center;">  </td> </tr> <tr> <td style="text-align: center;">⊙ - ⊕</td> <td style="text-align: center;">  </td> </tr> <tr> <td rowspan="2" style="text-align: center; vertical-align: middle;">C.C.W.</td> <td style="text-align: center;">⊙ - ⊕</td> <td style="text-align: center;">  </td> </tr> <tr> <td style="text-align: center;">⊙ - ⊕</td> <td style="text-align: center;">  </td> </tr> </tbody> </table> <p style="font-size: x-small; text-align: center;">VIEW FROM THE DIRECTION A</p>	Rotational direction	Signal	Output	C.W.	⊙ - ⊕		⊙ - ⊕		C.C.W.	⊙ - ⊕		⊙ - ⊕	
	Rotational direction	Signal	Output												
C.W.	⊙ - ⊕														
	⊙ - ⊕														
C.C.W.	⊙ - ⊕														
	⊙ - ⊕														
<b>RESOLUTION:</b>	Number of output pulses in 360° rotation, 12 pulses for each phase														

# TAIWAY ELECTRONICS COMPONENTS CO., LTD.

## 841 SERIES SPECIFICATION

**File No.:**

**841**

**Rev.: A**

**Page: 5 pages**

ELECTRICAL CHARACTERISTICS	CHATTERING:	<p>Measurement shall be done under the measuring circuit in Fig by rotating the shaft at a speed of 360° per second. Chattering is specified by the signal's passage time from 3.5 to 1.5 V or from 1.5 to 3.5 V of each switching position (code OFF→ON or ON→OFF).</p> <div style="text-align: center;"> </div> <div style="text-align: center;"> </div> <p>Note                      Code ON: It means that output voltage is lower than 1.5 V.                      Code OFF: It means that output voltage is higher than 3.5 V.</p>
	ROTATIONAL NOISE (Bounce):	<p>Rotational noise shall be specified by the time of voltage change with more than 1.5v in code-ON area. When the bounce has more than 1 ms between chattering (t1 or t3) in code-ON area, voltage change shall be regarded as this rotational noise (bounce). When rotational noise has less than 1.5V and more than 1 ms, this rotational noise is regarded as another rotational noise. t2 10ms</p>
	ROTATIONAL NOISE:	<p>The voltage change in code-OFF area shall be measured, not less than 3.5V</p>
	PHASE DIFFERENCE:	<p>Measurement shall be done under the measuring circuit in Fig by rotating the shaft at a speed of 360° per second. T1,T2,T3,T4 3ms</p> <div style="text-align: center;"> </div>

# TAIWAY ELECTRONICS COMPONENTS CO., LTD.

## 841 SERIES SPECIFICATION

**File No.:**

**841**

**Rev.: A**

**Page: 5 pages**

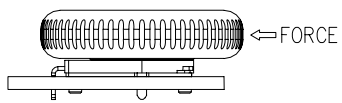
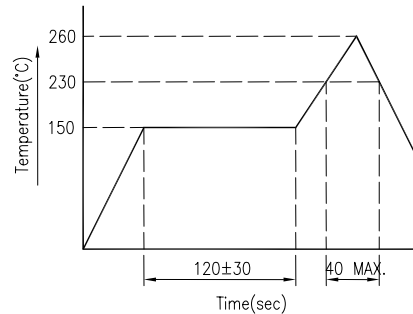
MECHANICAL CHARACTERISTICS	TOTAL ROTATIONAL ANGLE:	360° (endless)
	ROTATIONAL TORQUE:	3~60 gf.cm shaft shall be able to be rotated at the temperature of -10°C
	BENDING OF THE SHAFT:	<p>It adds in the point of the switch in the figure below after the terminal is soldered with a one side printed wiring board and the static load of 5Kgf is added in the direction of the arrow for 10± 1 seconds.</p> <div style="text-align: center;">  </div> <p>Shall result no wobble or bend</p>
	TERMINAL STRENGTH:	A static tensile load of 500gf shall be applied to the terminal in the axial direction for 10± 1 second, and then a static tensile load of 200gf in a perpendicular direction for 10 ± 1 seconds. This shall be no hindrance for electrical function, no damage and no break down of the terminal.
	VIBRATION:	<p>Vibration of 2 h specified below shall be applied in each of three mutually perpendicular directions for a total of 6 h.</p> <p>1 cycle: 10 Hz→55 Hz→10 Hz being swept linearly for 1 min.</p> <p>Amplitude: 1.5mm sine wave In accordance with JIS C 0040.</p>
SOLDER HEAT RESISTANCE:	<p>1. Soldering by hand: The specimen shall be put in laminated board (single copper foil board) with 1.6mm thick Each terminals shall be soldered with iron tip of 380+/-10 ° C for 3+1/0 second</p> <p>2. Soldering by automatic: Put in solder for 5 +1/-0 seconds at 255±5 Preheat temperature 110±20 for 30~60 seconds.</p> <p>3. Soldering by reflow:</p> <div style="text-align: center;">  </div>	

# TAIWAY ELECTRONICS COMPONENTS CO., LTD.

## 841 SERIES SPECIFICATION

**File No.:**

**841**

**Rev.: A**

**Page: 5 pages**

MECHANICAL CHARACTERISTICS	SOLDER- ABILITY:	Specimen shall be immersed into solution of rosin ethanol for 3-5 seconds, and specimen shall be put in the laminated board (1.6 mm thick), and then specimen shall be immersed into solder bath on to the bottom surface of board for 3 +/-0.5 seconds, as follows: Pb free solder (Sn-3Ag-0.5Cu) & Solder Temp.: 245+/-3 ° C. This shall result with no less than 90%, the surface immersed into solder shall be covered with new solder, expect for cut surface														
	DROPPING TEST:	The products shall be fallen down freely at any posture from 60 cm height to the concrete floor covered with vinyl tiles. This shall result no deformation on parts except for terminals														
RELIABILITY	COLD TEST:	Testing encoder being kept in the conditions at -10±3° C in temperature for 240 hours, then in a normal ambient condition for 1 hour, then to be measured within 1 hour														
	COLD TEST (STORAGE):	Testing encoder being kept in the conditions at -25±3° C in temperature for 72 hours, then in a normal ambient condition for 1 hour, then to be measured within 1 hour														
	HEAT TEST:	Testing encoder being kept in the conditions at 70±2° C in temperature for 240 hours, then in a normal ambient condition for 1 hour, then to be measured within 1 hour														
	HEAT TEST (STORAGE):	Testing encoder being kept in the conditions at 70±2° C in temperature for 72 hours, then in a normal ambient condition for 1 hour, then to be measured within 1 hour														
	HUMIDITY TEST:	Testing encoder being kept in the conditions at 40±2° C and 90~95% RH for 240 hours, then in a normal ambient condition for 1 hour, then to be measured within 1 hour														
	TEMPERATURE CYCLE:	The specimen shall be maintained at each temperature and duration specified in a table below for continuous 5 cycles, and then left in the standard conditions for 1 to 2 hours														
	<table border="1" style="margin-left: auto; margin-right: auto;"> <thead> <tr> <th style="width: 15%;">Order</th> <th style="width: 45%;">Temperature ( )</th> <th style="width: 40%;">Time (min)</th> </tr> </thead> <tbody> <tr> <td style="text-align: center;">1</td> <td style="text-align: center;">-10±3</td> <td style="text-align: center;">30~35</td> </tr> <tr> <td style="text-align: center;">2</td> <td style="text-align: center;">Std. Condition</td> <td style="text-align: center;">10~15</td> </tr> <tr> <td style="text-align: center;">3</td> <td style="text-align: center;">70±2</td> <td style="text-align: center;">30~35</td> </tr> <tr> <td style="text-align: center;">4</td> <td style="text-align: center;">Std. Condition</td> <td style="text-align: center;">10~15</td> </tr> </tbody> </table>		Order	Temperature ( )	Time (min)	1	-10±3	30~35	2	Std. Condition	10~15	3	70±2	30~35	4	Std. Condition
Order	Temperature ( )	Time (min)														
1	-10±3	30~35														
2	Std. Condition	10~15														
3	70±2	30~35														
4	Std. Condition	10~15														

# TAIWAY ELECTRONICS COMPONENTS CO., LTD.

## 841 SERIES SPECIFICATION

File No.:  
841

Rev.: A

Page: 5 pages

MATERIAL CHARACTERISTICS	ROTOR:	PA9T
	BODY:	PA9T
	BRACKET:	SPCE, Sn plated
	CONTACT PLATE:	PBS, Ag plated
	TERMINAL:	SPCC, Ag plated
PACKAGE IDENTIFI- CATIONS:	A label marking "RoHS compliant" will be attached to the carton box or the smallest package	

REV. 更改	DESCRIPTION 說明	ENG. 修改人	APPROVE 審核
------------	-------------------	-------------	---------------

CIRCUIT DIAGRAM

C.W. 12 PLUSE\*  
 C.C.W. T=30°  
 ONDUTY=50%=15°

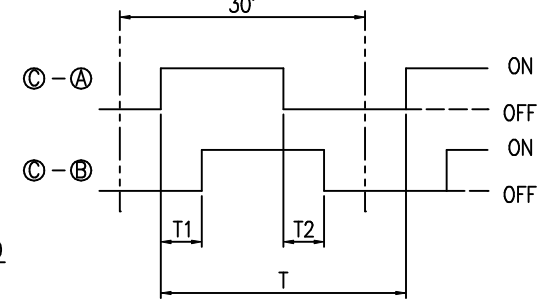

VIEW FROM THE DIRECTION A

P.C.B. LAYOUT

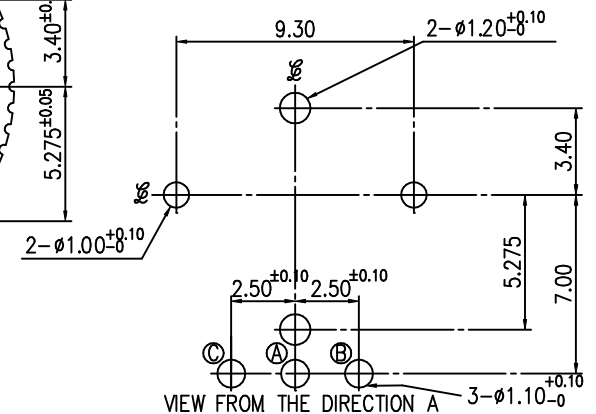

VIEW FROM THE DIRECTION A

SPECIFICATIONS:  
 1.RATING: 5VDC. 1mA.  
 2.INSULATION RESISTANCE: 50VDC-10MΩ MIN.  
 3.WITHSTAND VOLTAGE: 50VAC-1 MINUTE  
 4.ROTARY TORQUE: 3~60 gf.cm.  
 5.TOTAL ROTARY ANGLE: 360° (12 PULSE)  
 6.LIFE CYCLE: 20,000 CYCLES

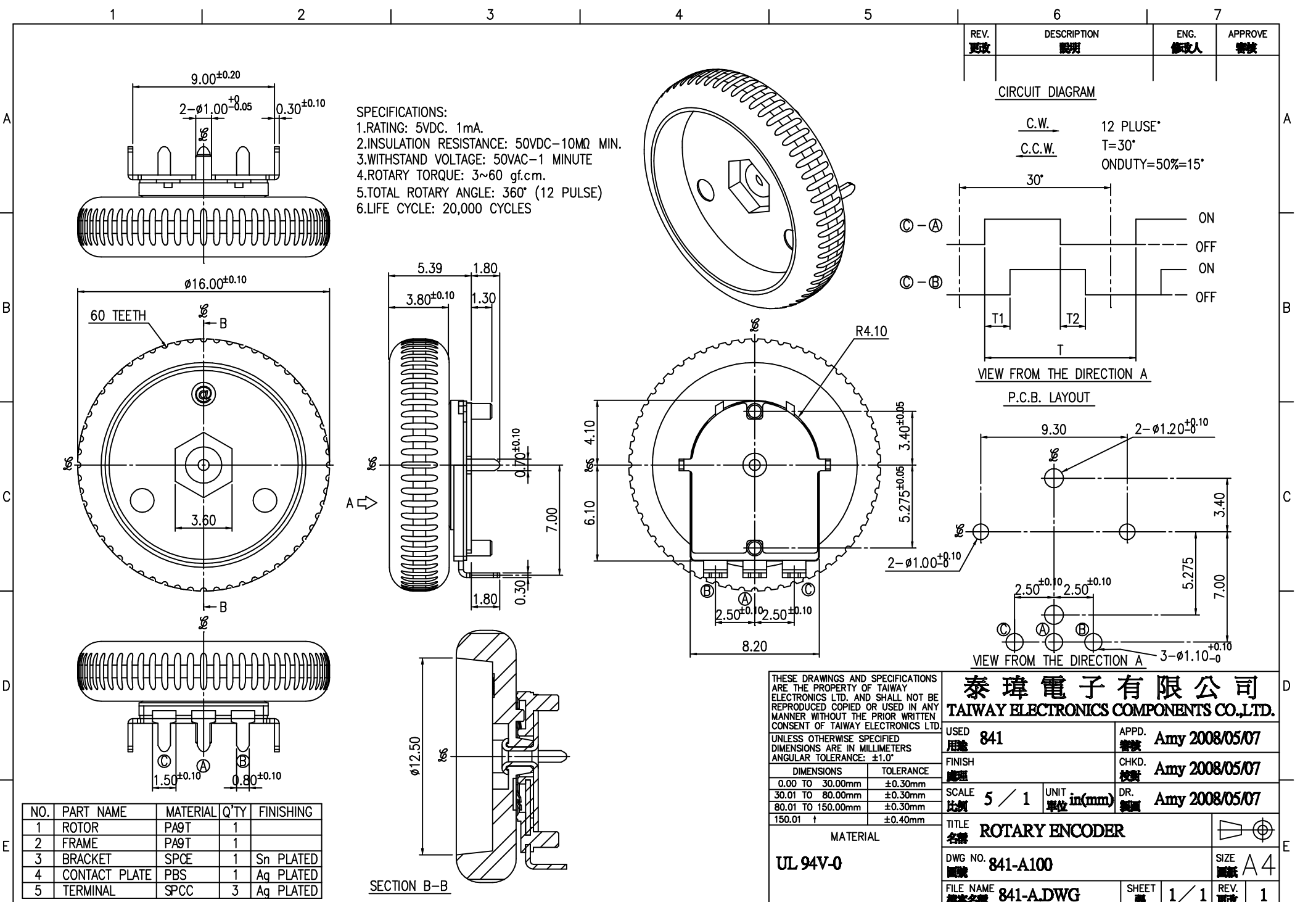

NO.	PART NAME	MATERIAL	Q'TY	FINISHING
1	ROTOR	PA9T	1	
2	FRAME	PA9T	1	
3	BRACKET	SPCE	1	Sn PLATED
4	CONTACT PLATE	PBS	1	Ag PLATED
5	TERMINAL	SPCC	3	Ag PLATED

THESE DRAWINGS AND SPECIFICATIONS ARE THE PROPERTY OF TAIWAY ELECTRONICS LTD. AND SHALL NOT BE REPRODUCED COPIED OR USED IN ANY MANNER WITHOUT THE PRIOR WRITTEN CONSENT OF TAIWAY ELECTRONICS LTD.

UNLESS OTHERWISE SPECIFIED DIMENSIONS ARE IN MILLIMETERS ANGULAR TOLERANCE: ±1.0°

DIMENSIONS	TOLERANCE
0.00 TO 30.00mm	±0.30mm
30.01 TO 80.00mm	±0.30mm
80.01 TO 150.00mm	±0.30mm
150.01 ↑	±0.40mm

MATERIAL  
**UL 94V-0**

**泰瑋電子有限公司**  
**TAIWAY ELECTRONICS COMPONENTS CO.,LTD.**

USED 用途	841	APPD. 審核	Amy 2008/05/07
FINISH 處理		CHKD. 校對	Amy 2008/05/07
SCALE 比例	5 / 1	DR. 製圖	Amy 2008/05/07

TITLE 名稱	ROTARY ENCODER		
DWG NO. 圖號	841-A100	SIZE 圖紙	
FILE NAME 檔案名稱	841-A.DWG	SHEET 張	1 / 1
		REV. 更改	1

REV. 更改	DESCRIPTION 說明	ENG. 修改人	APPROVE 審核
------------	-------------------	-------------	---------------

CIRCUIT DIAGRAM

C.W. 12 PLUSE\*  
C.C.W. T=30°  
ONDUTY=50%=15°

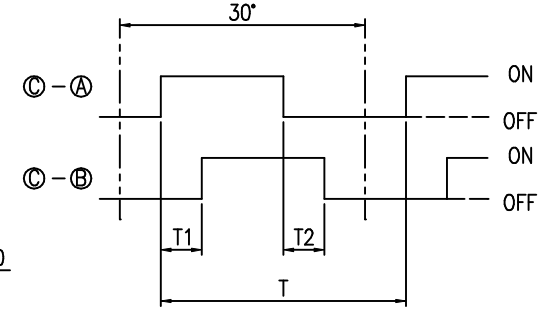

VIEW FROM THE DIRECTION A

P.C.B. LAYOUT

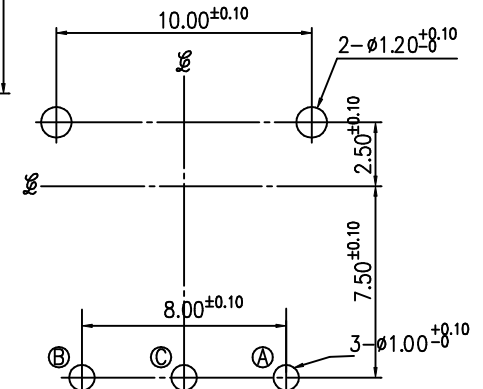

VIEW FROM THE DIRECTION A

SPECIFICATIONS:  
1.RATING: 5VDC. 1mA.  
2.INSULATION RESISTANCE: 50VDC-10MΩ MIN.  
3.WITHSTAND VOLTAGE: 50VAC-1 MINUTE  
4.ROTARY TORQUE: 3~60 gf.cm.  
5.TOTAL ROTARY ANGLE: 360° (12 PULSE)  
6.LIFE CYCLE: 20,000 CYCLES

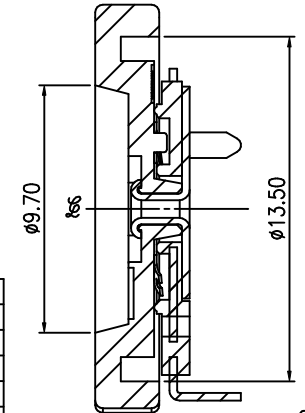
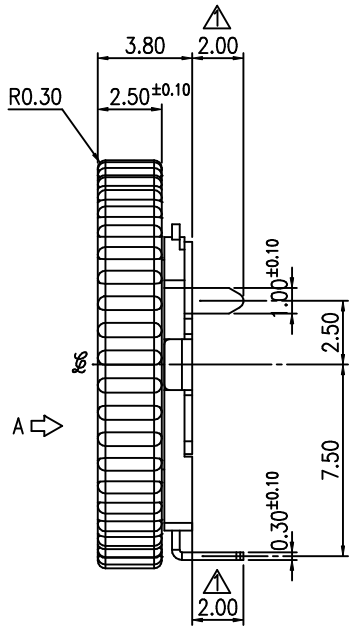
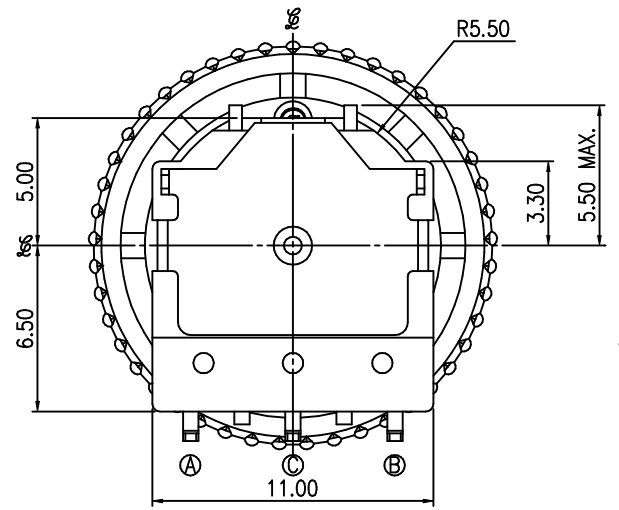
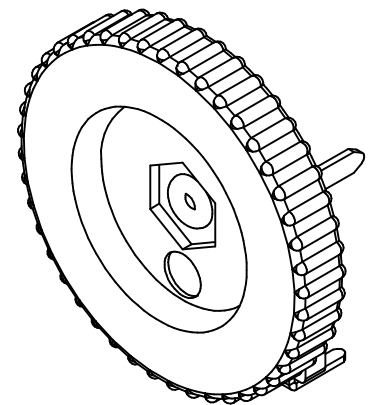

SECTION B-B

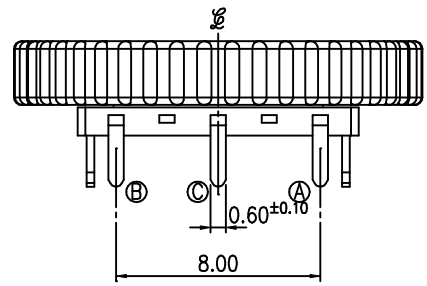
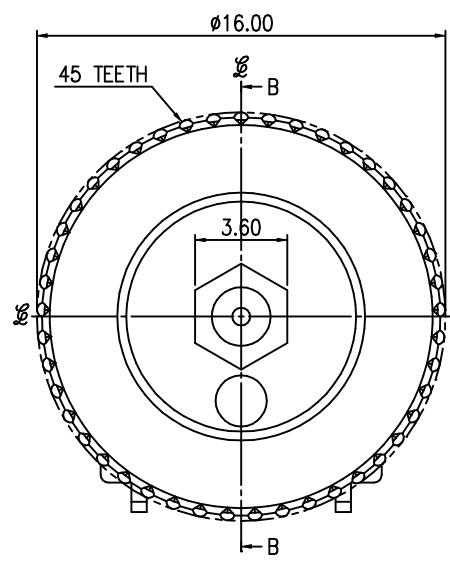
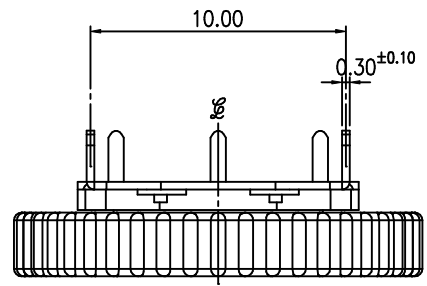

NO.	PART NAME	MATERIAL	Q'TY	FINISHING
1	ROTOR	PA9T	1	
2	FRAME	PA9T	1	
3	BRACKET	SPCE	1	Sn PLATED
4	CONTACT PLATE	PBS	1	Ag PLATED
5	TERMINAL	SPCC	3	Ag PLATED

THESE DRAWINGS AND SPECIFICATIONS ARE THE PROPERTY OF TAIWAY ELECTRONICS LTD. AND SHALL NOT BE REPRODUCED COPIED OR USED IN ANY MANNER WITHOUT THE PRIOR WRITTEN CONSENT OF TAIWAY ELECTRONICS LTD.

UNLESS OTHERWISE SPECIFIED DIMENSIONS ARE IN MILLIMETERS ANGULAR TOLERANCE: ±1.0°

DIMENSIONS	TOLERANCE
0.00 TO 30.00mm	±0.30mm
30.01 TO 80.00mm	±0.30mm
80.01 TO 150.00mm	±0.30mm
150.01 ↑	±0.40mm

MATERIAL  
**UL 94V-0**

**泰瑋電子有限公司**  
**TAIWAY ELECTRONICS COMPONENTS CO.,LTD.**

USED 用途	841	APPD. 審核	Amy 2008/05/07
FINISH 處理		CHKD. 校對	Amy 2008/05/07
SCALE 比例	5 / 1	DR. 製圖	Amy 2008/05/07

TITLE 名稱	ROTARY ENCODER		
DWG NO. 圖號	841-B100	SIZE 圖紙	
FILE NAME 檔案名稱	841-B.DWG	SHEET 張	1 / 1
		REV. 更改	1